

REV	DESCRIPTION	DATE
XI	First edition	

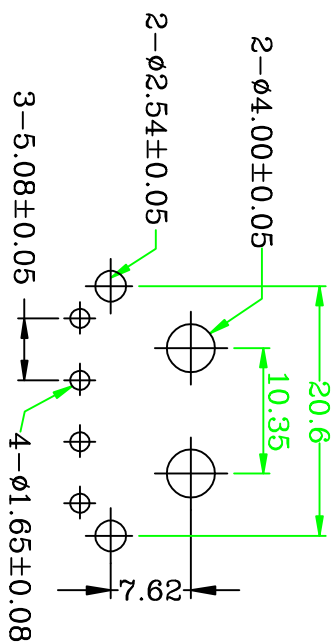

www.szjusun.cn

Suggest P.C.B.Layout

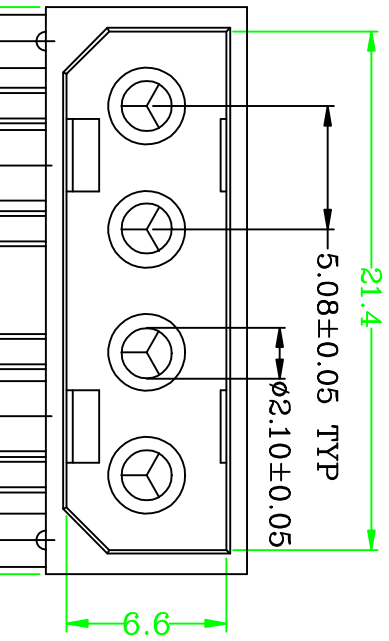
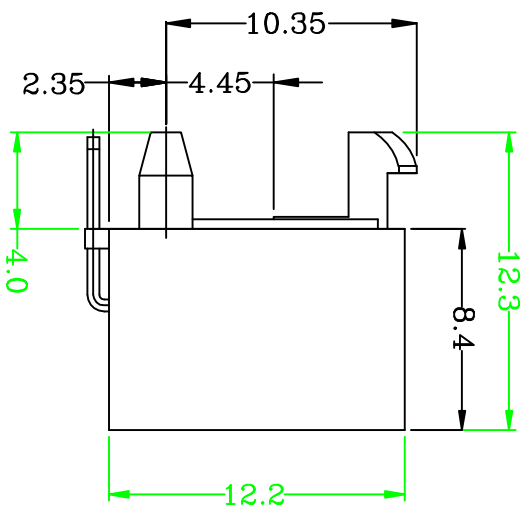
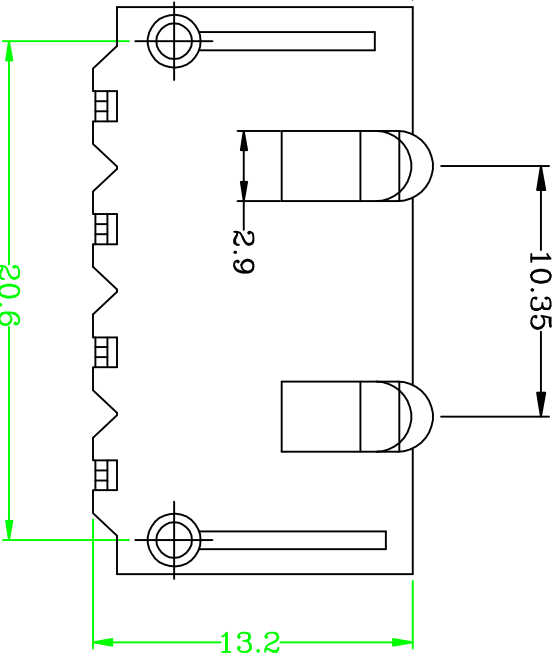

- 技术参数 SPECIFICATIONS**
- ◆ 间距: 5.08 Pitch: 5.08
 - ◆ 极数: 4 Poles: 4
 - ◆ 额定电压: AC, DC, 250V (250HZ有效值)
 - ◆ Voltage rating: AC, DC, 250V (250HZ)
 - ◆ 额定电流: 5.0A, AC, DC
 - ◆ Current rating: 5.0A, AC, DC
 - ◆ 耐压值: 1500V AC/minute
 - ◆ Withstand voltage: 1500V AC/minute
 - ◆ 工作温度: -25°C~+85°C
 - ◆ Working Temperature: -25°C~+85°C
 - ◆ 绝缘电阻: > 1000 ohm
 - ◆ Insulation resistance: > 1000 ohm
 - ◆ 接触电阻: < 0.02 oh
 - ◆ Contact resistance: < 0.02 oh
 - ◆ 适用印制板厚度: 1.6mm
 - ◆ Applicable PC board thickness: 1.6mm
- 材料 MATERIAL**
- ◆ 接触件: 磷青铜 (Phosphor bronze)
 - ◆ 塑胶本体: 尼龙, UL 94V-0
- 包装方式 PACKAGE**
- ◆ 袋装 Bag Package

JUSUN 钰赛实业(深圳)有限公司		TITLE: 大四P-4AW	
JUSAI INDUSTRIAL (SHENZHEN) CO.,LTD		PART NO.:	
USE:	MAT'L	APPD:	DWG NO.:
FINISH	FINISH	CHEKD:	SCALE
DR:	Q'TY	DR:	1:1
UNITS: mm			SHEET 1/1
			REV. XI