

No. of Contacts	Part No	DIMENSIONS	
		A	B
2	SM-2A	2.5	8.0
3	SM-3A	5.0	10.5
4	SM-4A	7.5	13.0
5	SM-5A	10.0	15.5
6	SM-6A	12.5	18.0
7	SM-7A	15.0	20.5
8	SM-8A	17.5	23.0
9	SM-9A	20.0	25.5
10	SM-10A	22.5	28.0
11	SM-11A	25.0	30.5
12	SM-12A	27.5	33.0

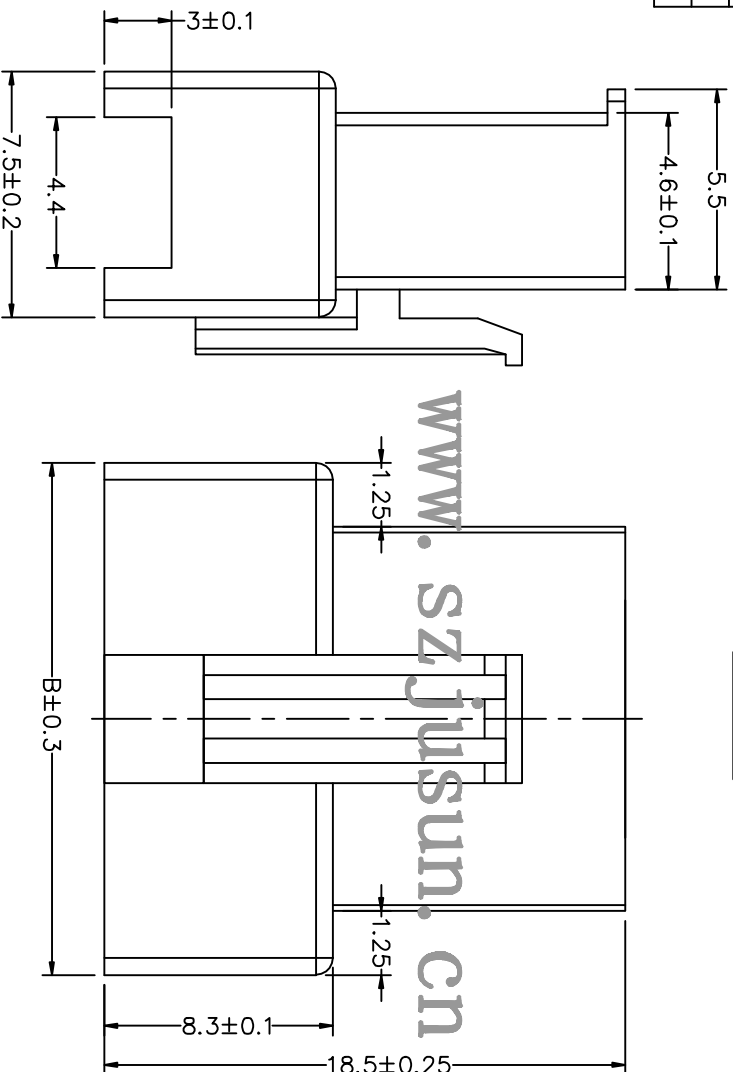
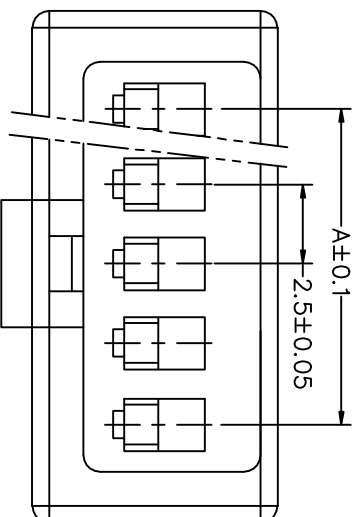

技术参数 SPECIFICATIONS

- ◆ 间距: 2.5 Pitch: 2.5
- ◆ 适用线规: AWG#28~#22
Applicable Wire: AWG#28~#22
- ◆ 额定电压: AC, DC, 250V (有效值)
Voltage rating: AC, DC, 250V(rms)
- ◆ 额定电流: 3.0A
Current rating: 3.0A
- ◆ 耐压值: 1000V AC/minute
Withstand voltage: 1000V AC/minute
- ◆ 工作温度: -25℃~+85℃
Working Temperature: -25℃~+85℃
- ◆ 绝缘电阻: > 1000 MΩ
Insulation resistance: > 1000MΩ
- ◆ 接触电阻: < 0.02 Ω
Contact resistance: < 0.02 Ω
- ◆ 适用印制板厚度: 1.6 mm
Applicable PC board thickness: 1.6 mm

材料 MATERIAL

- ◆ 绝缘座: 尼捷 UL94-0
Housing: Nylon UL94-0
- ◆ 端子: 磷青铜
Terminal: Phosphor bronze

JUSUN		JUSUN		JUSUN	
恒泰实业(深圳)有限公司 JUSUN INDUSTRIAL (SHENZHEN) CO.,LTD		恒泰实业(深圳)有限公司 JUSUN INDUSTRIAL (SHENZHEN) CO.,LTD		恒泰实业(深圳)有限公司 JUSUN INDUSTRIAL (SHENZHEN) CO.,LTD	
GENERAL TOLERANCE		SCALE		DRAWN	
XX. ± 0.25	XXX. ± 0.40	5=1	CHECK	DATE	DWG. NO.
X. ± 0.20	XXX ± 0.05	MM	APPROVE	DATE	G:\DWG\Production\SM-n*.DWG
.X ± 0.15	X' ± 2'	SIZE	DATE	PARTS NO.	SM-nA
.XX ± 0.08	X' ± 1'	A4	DATE	TITLE	REV.
塑胶检验图					A
SHEET					1/1