

REV	DESCRIPTION	DATE
XI	First edition	

**SPECIFICATIONS**

- Voltage rating: 250V AC,DC
- Current rating: 3A,AC,DC
- Withstanding Voltage: 1000V AC/minute
- Insulation resistance:1000M $\Omega$ min
- Temperature range:-25 $^{\circ}$ C - +85 $^{\circ}$ C
- Applicable PC board thickness:0.063"(1.6mm)
- Contact resistance:Initial Value/10m $\Omega$  max  
After environmental Texting/20m $\Omega$

**HOUSING**

- Poles:2-16
- Material:Nylon 66, UL94V-0
- QTY: 500, 1000 pcs/bag

www.szjusun.cn

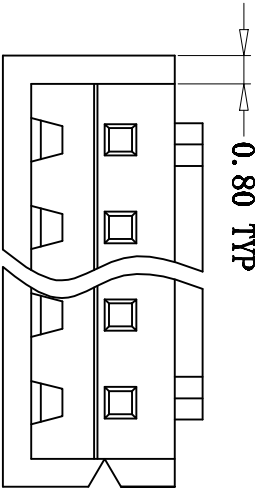
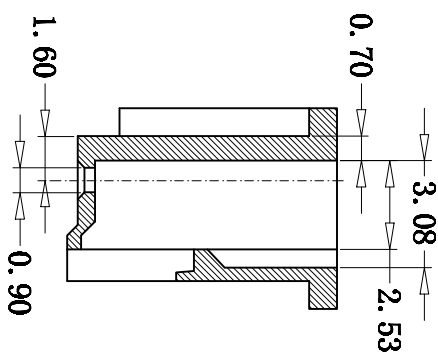
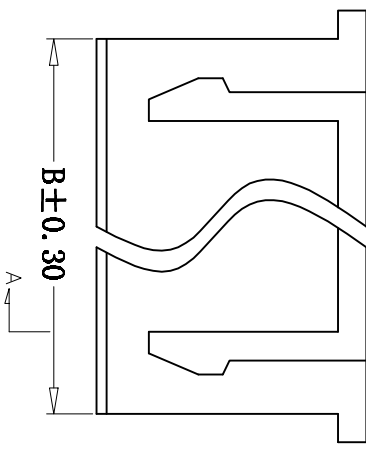
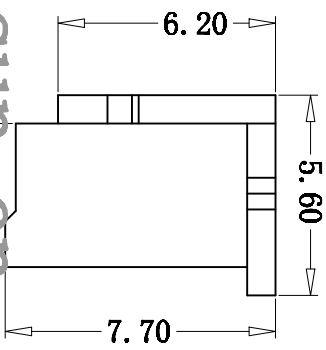
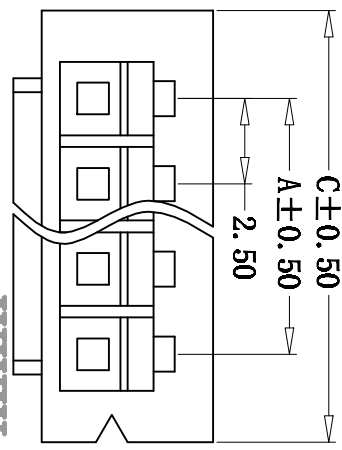

NO	PART NO	DIMENSION (mm)		
		A	B	C
2	XH-2T	2.50	5.70	7.30
3	XH-3T	5.00	8.20	9.80
4	XH-4T	7.50	10.70	12.30
5	XH-5T	10.00	13.20	14.80
6	XH-6T	12.50	15.70	17.30
7	XH-7T	15.00	18.20	19.80
8	XH-8T	17.50	20.70	22.30
9	XH-9T	20.00	23.20	24.80
10	XH-10T	22.50	25.70	27.30
11	XH-11T	25.00	28.20	29.80
12	XH-12T	27.50	30.70	32.30
13	XH-13T	30.00	33.20	34.80
14	XH-14T	32.50	35.70	37.30
15	XH-15T	35.00	38.20	39.80
16	XH-16T	37.50	40.70	42.30

**JUSUN** 钜赛实业(深圳)有限公司  
JUSAI INDUSTRIAL (SHENZHEN) CO.,LTD

L ±	L' ±	MAT'L	APPD:	PART NO.:	XH-nY
.I ± 0.25	.I' ± 0.1"	/		CIS PART NO.:	
.II ± 0.10	.II' ± 0.05"	FINISH	CHKD:	DATE	VERSION
.III ± 0.05	.III' ±	/		2017.07.08	VI.0
UNITS:	UNITS:	Q'TY	DR:	SCALE	SHEET
				1:1	REV. XI