

80-WVBSN-1J

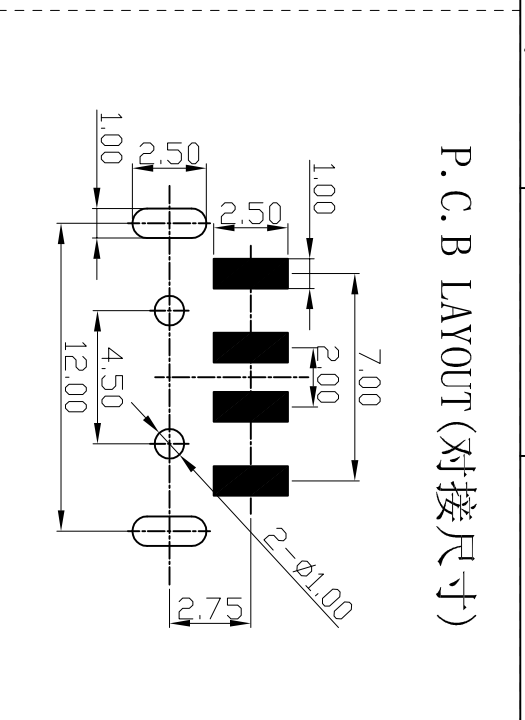

www.szjusun.cn

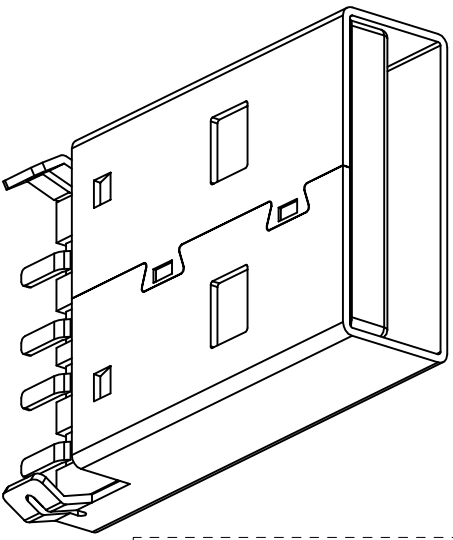
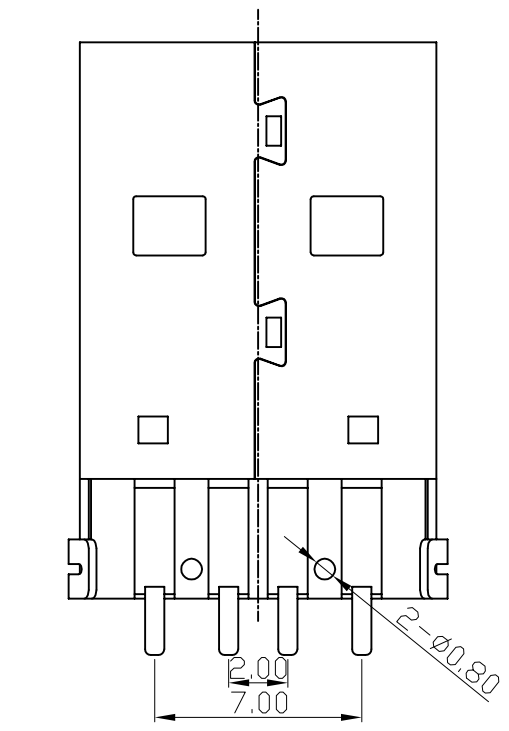
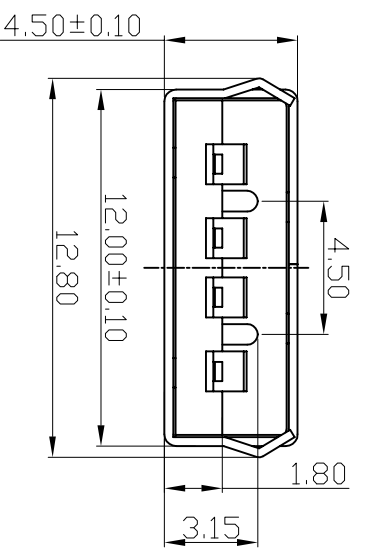
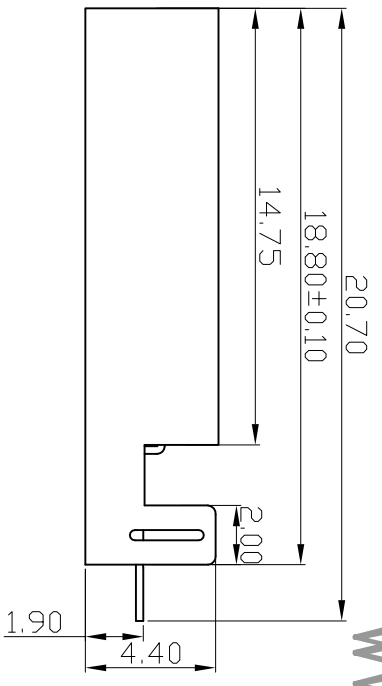

技术要求

1. ELECTRICAL CHARACTERISTICS(电气性能):

- 1.1 Rating(额定值): DC 0.2A 48V
  - 1.2 Contact Resistance(接触电阻):  $\leq 50m\Omega$
  - 1.3 insulation Resistance(绝缘电阻):  $\geq 100M\Omega$
  - 1.4 Actuating Force(插拔力): 0.7~4kg
  - 1.5 Withstand Voltage(耐压): AC500V(50Hz)/min
  - 1.6 Life(寿命): 10,000 Cycles MIN(大于10,000次)
- 2、ELECTRICAL temperature rang(使用温度范围): -30° C~+70° C

公差对照表

尺寸范围	公差范围	视角	批准	名称
0~10	±0.1		审核	USB AM 180° SMT沉板式
10~20	±0.2			
20~40	±0.3	MM	设计	型号 USBAM-06
40~60	±0.5			
60~80	±0.5			
80~100	±1	比例 4:1	设计	编辑日期
120~140	±1.5			