

3D VIEW

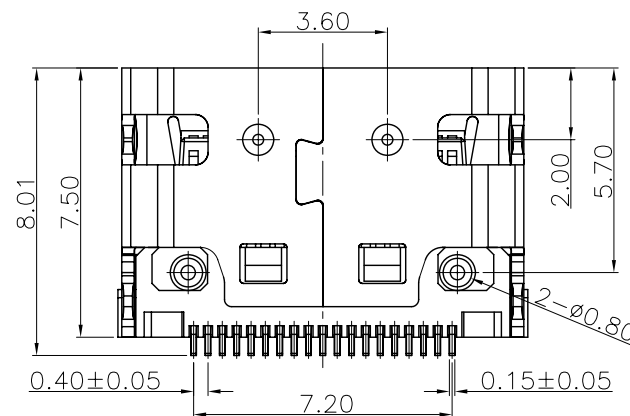

A	新版发行	chu	2011-03-02
Rev. 版本	CHANGE DESCRIPTION 变更内容	REVISOR 制/修订人	DATE 日期

MATERIAL	TOLERANCE UNSPECIFIED			巨赛实业(深圳)有限公司 JUSAI INDUSTRIAL (SHENZHEN) CO.,LTD	SCALE 1:1	UNIT mm
	0.0 ±0.30	0.° ±2°				
	0.00 ±0.20	.0° ±1°				
	0.000 ±0.10	.0° ±0.5°				
FINISH	DRAWN Chu	11/03/02	NAME HDMI C/F TYPE SMT TYPE (HSC Series)		SHEET 1/2	
	DESIGNER Chu	11/03/02	DRAWING NO. HHF-1XX000-XSC			
	CHECKED		REV A			
	APPROVED					

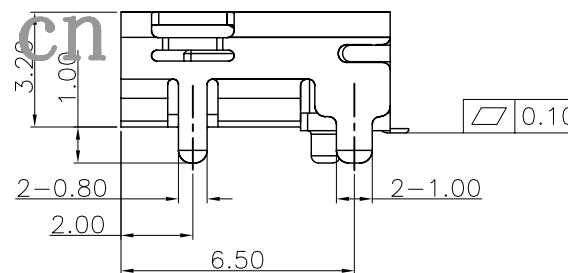
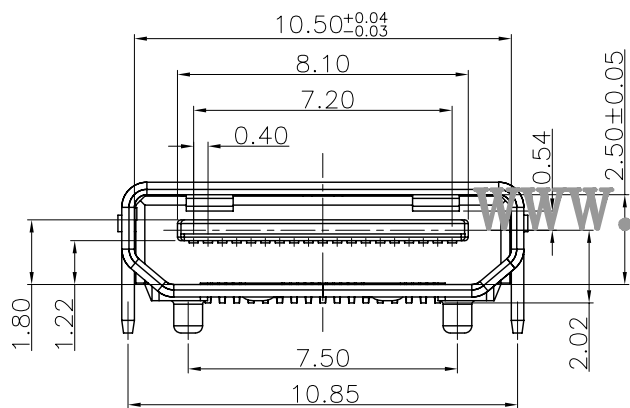
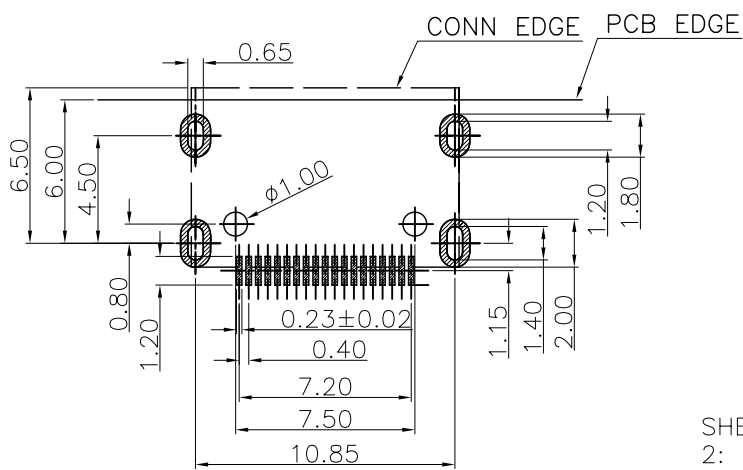

RECOMMENDED PCB LAYOUT(TOP VIEW)
(THICKNESS=0.8±0.05mm)
TOLERANCE = ±0.05

NOTES:

1. MATERIAL:
 - 1.1 HOUSING: LCP, BLACK, UL94V-0
 - 1.2 SHELL: BRASS
 - 1.3 TERMINAL: PHOSPHOR BRONZE
 - 1.4 MYLAR:
2. PLATING:
 - 1.1 SHELL: GOLD PLATING OVER NICKEL
 - UNDERPLATED/NICKEL PLATING OVER ALL
 - 1.2 TERMINAL: GOLD PLATING ON CONTACT
 - AREA AND TIN PLATING ON
 - SOLDER AREA, NICKEL UNDERPLATING OVER ALL
3. All RAW MATERIAL, COMPONENTS, AND PROCESS MUST MEET HAZARD SUSTAIN FREE PER RoHS & REACH STANDARD.

4. P/N: HHF-1XX000-XSC

SHELL MATERIAL & PLATING CODE:
 2: MATERIAL: COPPER ALLOY
 NICKEL PLATING WITHOUT FLANGE
 6: MATERIAL: COPPER ALLOY
 GOLD PLATING WITHOUT FLANG

PACKAGING CODE
 1: TARY PACKING
 2: TAPE REEL PACKAGEING
 3: TUBE PACKING

MYLAR:
 0: WITHOUT MYLAR
 1: WITH MYLAR

www.szjusun.cn

TERMINAL CONTACT AREA PLATING CODE:
 1: CONTACT AREA: GOLD FLASH
 SOLDER AREA: GOLD FLASH
 2: CONTACT AREA: 3u" GOLD
 SOLDER AREA: GOLD FLASH
 A: CONTACT AREA: GOLD FLASH
 SOLDER AREA: MATTE TIN 100u"
 B: CONTACT AREA: 3u" GOLD
 SOLDER AREA: MATTE TIN 100u"

PIN	Signal Name	PIN	Signal Name
1	TMDS DATA2 Shield	11	TMDS Clock+
2	TMDS DATA2+	12	TMDS Clock-
3	TMDS DATA2-	13	DDC/CEC Ground
4	TMDS DATA1 Shield	14	CEC
5	TMDS DATA1+	15	SCL
6	TMDS DATA1-	16	SDA
7	TMDS DATA0 Shield	17	Reserved(in cable but N.C.on device)
8	TMDS DATA0+		
9	TMDS DATA0-	18	+5V Power
10	TMDS Clock Shield	19	Hot Plug Detect

A	新版发行	chu	2011-03-02
Rev. 版本	CHANGE DESCRIPTION 变更内容	REVISOR 制/修订人	DATE 日期

MATERIAL	TOLERANCE UNSPECIFIED		恒赛实业(深圳)有限公司 JUSAI INDUSTRIAL (SHENZHEN) CO.,LTD			
	0.0 ±0.30	0. ±2'				
	0.00 ±0.20	.0' ±1'				
	0.000 ±0.10	.0' ±0.5'				
FINISH	DRAWN	Chu	11/03/02	NAME	HDMI C/F TYPE SMT TYPE (HSC Series)	SHEET 2/2
	DESIGNER	Chu	11/03/02			
	CHECKED			DRAWING NO.	HHF-1XX000-XSC	REV A
	APPROVED					