

NOTE:  
 1.MATERIAL AND FINISH SEE THE TABLE.  
 2.MECHANICAL CHARACTERISTICS  
 INSERTION FORCE: 44.1N MAX  
 EXTRACTON FORCE: 5N MIN(AFTER 5000 CYCLES 3N MIN.), 25N MAX.  
 MATING CYCLE:5000 CYCLES  
 3.ELECTRICAL CHARACTERISTICS  
 RATING CURRENT: 0.5A  
 RATING VOLTAGE: 40V  
 CONTACT RESISTANCE: 10 MILLOHMS OHMS MAX (EXCLDUING CONDUCTOR RESISTANCE)  
 INSULATION RESISTANCE:  
 a, UNMATED: 100M OHMS MIN AT 500 VDC  
 b, MATED: 10M OHMS MIN AT 150 VDC  
 DIELECTRIC WITHSTANDING VOLTAGE:  
 250V AC/1MINUTE  
 OPERATING TEMPERATURE: -20°C--+85°C  
 STORAGE TEMPERATURE: -20°C--+65°C

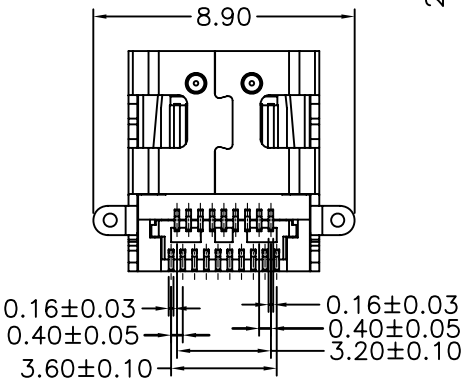
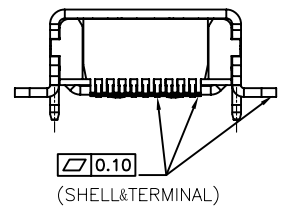
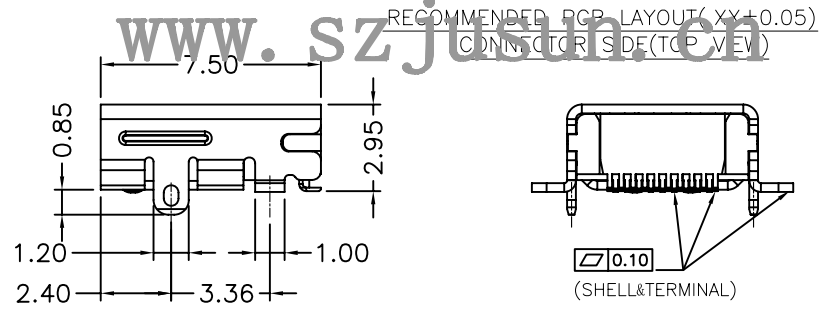
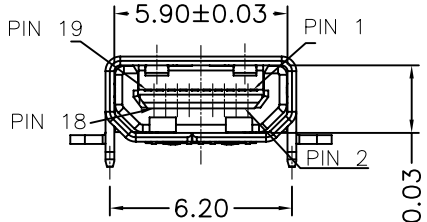

PART NO:  
 HHF-12X000-XSD  
 PACKAGING CODE  
 1: TARY PACKING  
 2: TAPE REEL PACKAGEING  
 3: TUBE PACKING  
 TERMINAL CONTACT AREA PLATING CODE:  
 1: CONTACT AREA: GOLD FLASH  
 SOLDER AREA: GOLD FLASH  
 2: CONTACT AREA: 3u" GOLD  
 SOLDER AREA: GOLD FLASH  
 A: CONTACT AREA: GOLD FLASH  
 SOLDER AREA: MATTE TIN 100u"  
 B: CONTACT AREA: 3u" GOLD  
 SOLDER AREA: MATTE TIN 100u"

PIN	Signal Assignment	PIN	Signal Assignment
1	Hot Plug Detect	2	Utility
3	TMDS Data2+	4	TMDS Data2 Shield
5	TMDS Data2-	6	TMDS Data1+
7	TMDS Data1 Shield	8	TMDS Data1-
9	TMDS Data0+	10	TMDS Data0 Shield
11	TMDS Data0-	12	TMDS Clock+
13	TMDS Clock Shield	14	TMDS Clock-
15	CEC	16	DDC/CEC Ground
17	SCL	18	SDA
19	+5V Power		

MATERIAL	TOLERANCE UNSPECIFIED 0.0 ±0.30 0° ±2° 0.00 ±0.20 .0° ±1° 0.000 ±0.10 .0° ±0.5°	钜赛实业(深圳)有限公司 JUSAI INDUSTRIAL (SHENZHEN) CO.,LTD	SCALE 1:1	UNIT mm
	FINISH		NAME HDMI D/F TYPE SMT TYPE (HSD Series)	
	DRAWN Chu 14/01/15	CHECKED	SHEET 1/1	
	DESIGNER Chu 14/01/15	APPROVED	DRAWING NO. HHF-1XX000-XSD	REV B

B	模具改善, 取消外铜壳撕破凸肋	chu	2014-01-16
A	新版发行	chu	2011-10-06
Rev. 版本	CHANGE DESCRIPTION 变更内容	REVISOR 制/修订人	DATE 日期